

# Determinants of Sustainable Supply Chain Performance: The Role of Corporate Entrepreneurship in Indecision Textile Companies

Endang Noerhartati<sup>\*1</sup>, Yoyok Soesatyo<sup>#2</sup>, Moedjito<sup>#3</sup>, Toho Cholik Mutohir<sup>#4</sup>, Amrozi Khamidi<sup>#5</sup>

<sup>\*1</sup>Department of Education Management, Universitas Negeri Surabaya, Indonesia; Departement of Agroindustrial Technology, Universitas Wijaya Kusuma Surabaya, Indonesia

Corresponding author: E-mail: endang.18006@mhs.unesa.ac.id; endang\_noer@uwks.ac.id

<sup>#2,3,4,5</sup>Department of Education Management, Universitas Negeri Surabaya, Indonesia

**Abstract-** This study examined various factors which may enhance the sustainable supply chain activities in Indonesian textile companies. Due to the lack in supply chain operations, the business performance of Indonesian textile companies was not up to the mark. A survey was carried out to collect the primary data. For survey purpose, total 300 questionnaires were distributed among the employees of Indonesian textile companies. By using the Smart PLS 3.0, five hypotheses were tested. During this study, it was revealed that management support and sufficient project time has important role in sustainable supply chain. Supportive organization culture has important role to enhance the positive effect of management support and sufficient project time on sustainable supply chain. It is recommended to the Indonesian textile companies to focus on management support, sufficient project time and organization culture to support sustainable supply chain performance. Therefore, this study is important for the practitioners to enhance textile company's performance by promoting sustainable supply chain activities.

**Keywords;** Sustainable supply chain, sufficient project time, management support, organization culture, textile industry.

## 1. Introduction

Supply chain is an integral part of various manufacturing companies [1], particularly, it is most important for textile companies [2] where the supply chain is the backbone of operations success [3]. With ineffective supply chain, the business performance achievement for textile companies is a challenge. Therefore, it is quite important for textile companies to have a good supply chain system. This argument is also supported by various other studies in the literature by highlighting the importance of supply chain for textile industry [4].

Various companies are lacking in business performance due to ineffective supply chain. According to the literature, Indonesian textile companies are facing diverse issues related to the supply chain. Due to the lack in supply chain operations, the business performance of Indonesian textile companies was not up to the mark [5]. Increase in the issues of supply chain can decrease performance. Importance of supply chain network in the

textile industry is highlighted in Figure 1. This shows that supply chain in textile industry involves all the aspects of manufacturing including all the activities from raw material to the distribution of complete goods. Therefore, in textile companies, supply chain is important from start to end. Low performance in any area has the potential to decrease the overall performance.

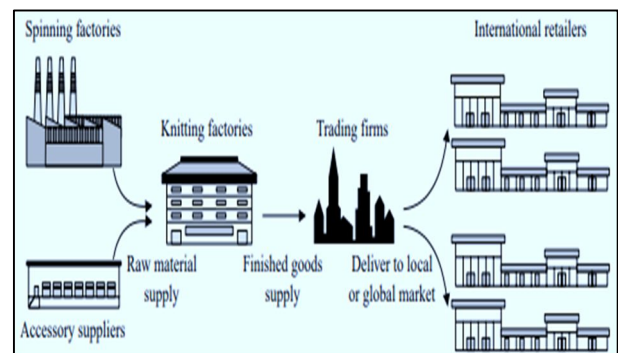

**Figure 1.** Supply chain network in the textile industry  
**Source:** [2]

However, all these issues of supply chain can be managed with the help of better corporate entrepreneurship activities. To define corporate entrepreneurship [6] stated that it includes situations where first, a new business is initiated or started by an established organization, second, the new ideas are advocated by one or more than one individual and third, an entrepreneurial philosophy pervades the outlook and operations of the whole organization. Corporate entrepreneurship always shows positive effect on business activities [7]. It has the ability to foster supply chain activities, as it has important link with supply chain [8-10].

Therefore, objective of this study is to inspect the role of corporate entrepreneurship on sustainable supply chain performance among Indonesian textile companies. This study investigated the effect of three corporate entrepreneurship dimensions on supply chain. These dimensions are; management support, sufficient time for project and organization culture. According to the previous studies, these are the important elements of corporate entrepreneurship having positive role on

business [11, 12]. Various studies are available in the literature on corporate entrepreneurship [13, 14], however, these studies did not discuss the role of corporate entrepreneurship in supply chain activities. Various studies also discussed the textile industry in Indonesia [15, 16], still, these studies missed the role of corporate entrepreneurship in supply chain performance. Therefore, this study has important contribution to the literature.

## 2. Literature Review

Corporate entrepreneurship is defined, by many researchers, as a assurance to produce entrepreneurial environment in a company to foster innovation, proactiveness and premeditated risk-taking [17]. The philosophy of corporate entrepreneurship is incorporated in the organization so that organization can be more responsive to environmental conditions, which change rapidly, by developing unique solutions (i.e product/services, procedures, structures) and continuously exploiting prospects with acceptance of risk of failure. There exists a strong correlation of the formalization and corporate entrepreneurship. Some degree of formalization increases corporate entrepreneurship. No matter it's about product, service, process, strategy, structure or behaviour, something common in major conceptualization of corporate entrepreneurship is

innovation. As a result, corporate entrepreneurship is considered as the process enhancing firm's ability for acquiring and utilizing the firm member's innovative skills [14].

Corporate entrepreneurship can be any of the three forms, individually or collectively which included (1) novel strategic way (2) inventiveness, and (3) independent business creation [11]. More and more attention has been paid to corporate entrepreneurship concept during the last few years. The concept of corporate entrepreneurship is adopted here as the behaviour of a firm which reflect its orientation towards entrepreneurship. Corporate entrepreneurship as set of strategies which are employed by a well-known firm for encouraging growth as well as development of its own. Based on the plenty of evidence, it can be concluded that due to its indispensable role in the sustainable existence and overall development of an enterprise, the realm of corporate entrepreneurship needs more attention for further understanding of its groundings, particularly in the area of supply chain. As the corporate entrepreneurship also has significant role with supply chain [8]. It is important in supply chain as it has positive role in firm performance [18]. In this study, three corporate entrepreneurship factors are considered; management support, sufficient project time and organization culture. It is highlighted in the study framework (Figure 2).

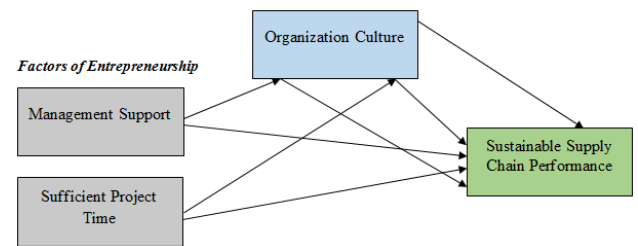

Figure 2. Theoretical Framework of the Study

### 2.1. Management Support

According to [19] management support denotes to encouragement and advancement of the entrepreneurial actions and behaviours. This suggests that support would be in the shape of providing psychological backing and resources [19]. The literature supports the notion that administrative support helps organizations in improving their performance particularly this is found helpful in promoting innovative outcomes. Therefore, present study draws upon the premises of the definition provided by [19] in operationalizing management support for its further investigation with business performance.

It is also evident that management support has important role in supply chain activities [20]. Management support has been deemed as one of the very critical factors that facilitates performance of supply chain. The literature on organizational management has explained managerial support into different aspects. Management support is defined as the extent where an organization institutes an environment that enables the support towards its employees (in managerial or nonmanagerial positions); besides that, it establishes trust, and cooperation for accomplishing organizational goals which facilitate supply chain. On the same lines, top management support could potentially influence employees (regardless of rank) to create positive attitude towards adopting news ideas and embrace innovation. Further stating these researchers have explained this could be possible when management would provide resources and other necessary support. In addition to this, management support is an

essential factor for idea generation, idea development and its implementation. Similarly, it is suggested that the top management support is very important; top management support accelerates the procedure of absorbing new knowledge [12] which enhance supply chain operations.

The review of these and other studies suggest that top management support is an integral factor that could potentially influence the business performance directly or indirectly through supply chain. Further to this, literature suggested that for the promotion of corporate entrepreneurial activities the willingness of management is very necessary. This support is demonstrated by organization's upper management, clearly promoting entrepreneurial behaviour in championing ideas which are innovative and ensure the availability of necessary resources for taking entrepreneurial actions by facilitating supply chain. There are several empirical evidences to support this claim. As studies shows positive role of management support in supply chain [21, 22].

There is a relationship between innovation (a primary facet of corporate entrepreneurship) and

managerial attitudes (backing the innovation). There is positive impact of managerial behaviours (who exhibit entrepreneurial behaviour) on their employees (subordinates) who reported increase in the job satisfaction level. It is suggested by the literature that leaders should set goals, reinforce positively, give feedback, emphasize individual responsibility and reward based on performance. As it has important relationship with supply chain of any company. Better management always lead to the better organizational activities [23]. Especially, it is important in textile industry of Indonesia where the supply chain activities contain low quality. Therefore, management support in respect to the corporate entrepreneurship has positive role in business [7].

Organizational support is reported as a critical dimension of corporate entrepreneurship by many researchers. Support in terms of training and trust for individuals within the organization to identify unseen opportunities to support resource accessibility is proposed to have positive influence over organizational entrepreneurial activities and behaviours. The empirical evidence is provided by other studies for this linkage. For the development of corporate entrepreneurial activities and improvement in firm performance as well as profitability organizational support is critical dimension, or even a necessary condition [11] which has role in supply chain.

**H1:** Management support has relationship with sustainable supply chain performance.

## 2.2. Sufficient Project Time

According to [19], time availability refers to employee perception regarding their organization that it will provide sufficient extra-time to pursue innovation and other organizational outcomes. Supporting this notion, however, various studies recommend that top management should analyse workload for ensuring that employees would have enough time to look for innovation and other organizational outcomes related with performance. This factor to time availability has positive role in supply chain activities of textile companies.

Past research suggested that in organizations the employees (regardless of position) should be provided abundance of free time. This free time could help employees to perform better on their assigned tasks which would ultimately improve business performance particularly in the form of bringing innovation. The factor of time availability has been given much importance as it is directly concerned with employees and manager's daily tasks and responsibilities. As the time has significant role in supply chain projects [24]. This factor has been researched with many organizational factors; common among them is the factor of innovation. Similarly, it is reported that the importance of time availability with regards to learning and acquisition of new knowledge is also important in supply chain.

Moreover, while explaining the importance of time availability it is suggested that employees

might feel threatening due to lack of time availability for accomplishing their respective tasks assigned to them

[11]. Therefore, it is essential for top management to appropriately look into time availability issue; as this issue is directly concerned with employee motivation and plays critical role in alleviating their work stress by increasing or decreasing the satisfaction level. As the employee satisfaction has crucial role in jobs [25] of supply chain management. In addition to what managers should be doing on their jobs they need to have enough time for a thought over what they should be doing and how they should do it. The above arguments from the literature have simplified the essence of time availability for better business performance and other performance related outcomes.

**H2:** Sufficient project time has relationship with sustainable supply chain performance.

## 2.3. Organization Culture

Organizational culture (OC) is the system of norms and values which is common among organization's employees and it determines the attitudes and approaches of organizational members towards confronting different problems in an organization. More recently, [26] while investigating the role of organizational culture on entrepreneurial orientation with the sample of German and Thai companies have suggested that the two are complimentary to each other. These scholars have further suggested that the firms should harvest appropriate organizational culture to advance in entrepreneurial orientation (corporate entrepreneurship). However, various studies also supported the notion that organizations do have varying cultures and those cultures are also at large influenced by the national cultures (a broader perspective of culture at a country level) therefore it is necessary to investigate the influence of organizational culture on corporate entrepreneurial practices in a given company under a give national culture.

Organization culture system argued that two interrelated sets of systems can have a great influence on an organization's culture. The first among them is the system, which is in-lined with typology of culture. This system consists of strategies, policies, structures and management practices of an organization and is aligned with the classic theory of management

(CTM). The focus of this CTM has been on achieving the organizational goals with the focus on task orientation. These systems of organization culture have significant influence on supply chain of any firm. Particularly, it is important for textile supply chain, as the organization culture has relationship with supply chain [27].

The second system which influences organization culture is the organization's belief system consisting of ideologies and values. However, scholars suggest that the responsibility of the development of organizational culture is central to top management. From setting organizational goals till communicating them effectively to all people concerned with an organization is the leader's responsibility [28]. Since long time, the organizational culture has been reported as imperative construct having its great influence on many individual behaviours. Moreover, the organizational culture has played significant role in understanding individual variables for

instance commitment, job-satisfaction, self-efficacy, and collective efficacy. For example, studies while investigating the organizational culture's influence over employee behaviours in the workplace, reported that the clan and adhocracy types of culture enhance job satisfaction of employees. With the well-established organizational culture, the organizations not only differentiate themselves from their rivals, but they also establish a sense of identity of an organization through better supply chain, resulting an increase in overall commitment to the organizational goals as well as objectives. [29] supported this notion stating organizational culture as glue for binding all individuals, activities, and behaviours together through a set of standards that determine the acceptable sets of behaviours. All these factors have significant influence on supply chain of Indonesian textile companies. As it is revealed that supply chain and organisation culture have direct relationship [30].

**H3:** Organization culture has relationship with sustainable supply chain performance.

**H4:** Organization culture mediates the relationship between management support and sustainable supply chain performance.

**H5:** Organization culture mediates the relationship between sufficient project time and sustainable supply chain performance.

### 3. Research Methodology

The objective of the present study was to test a hypothesized structural model. The model theorized that organizational culture has a mediation effect on the relationship between corporate entrepreneurship and sustainable supply chain. Looking into it, a total number of five hypotheses were formulated and tested. Further, on the basis of developed research model, the current study focused on theory testing and not developing a new theory. Therefore, the present study employed the deductive research approach. Further, following on the philosophical conventions as provided above, the current study adopted the positivist paradigm, based on objectivism as the underlying ontological as well as epistemological positions.

The most widely used approach for business research is survey design, which is the best method to study and describe large populations quickly and at a relatively low cost. In fact, these surveys can be adapted to almost any of the research settings due to their versatility. Most surveys have the central objective of investigating the relationships between variables. The use of surveys has been essentially important in helping to test hypothesis, describing populations, developing useful measurement scales, evaluating programs, building models of human behaviour and to make other methodological improvements business research area. Thus, this study used survey method to collect the data [11].

For survey purpose, total 300 questionnaires were distributed among the employees of Indonesia textile companies. Population of the study was textile companies of Indonesia. Respondents of the study were those employees which were working in supply chain department of textile companies. Form total 300 questionnaires, 190

questionnaires were returned which were completely filled and used for data analysis to test hypotheses. Moreover, 7-point Likert scale was used in this study to collect the data.

### 4. Data Analysis and Findings

Before to start the data analysis, data screening was carried out to check the missing value and outlier in the data. As the both missing value and outlier has the potential to change the results. It is shown in Table 1. Moreover, while using PLS, normality of the data has no issue, as PLS is suitable to handle non-normal data [31].

**Table 1.** Data Screening

	No.	Missing	Mean	Median	Min	Max	SD	Kurtosis	Skewness
MS1	1	0	5.261	6	1	7	1.727	0.578	-1.14
MS2	2	0	5.657	6	1	7	1.607	1.428	-1.41
MS3	3	0	5.627	6	1	7	1.651	2.053	-1.589
MS4	4	0	5.276	6	1	7	1.681	0.191	-0.987
MS5	5	0	5.358	6	1	7	1.734	0.684	-1.148
MS6	6	0	5.172	6	1	7	1.641	-0.162	-0.801
SPT1	7	0	5.119	6	1	7	1.869	-0.253	-0.89
SPT2	8	0	5.119	6	1	7	1.653	0.323	-1.015
SPT3	9	0	5.052	5	1	7	1.703	-0.283	-0.623
SPT4	10	0	5.336	6	1	7	1.714	0.331	-1.02
SPT5	11	0	5.052	5	1	7	1.742	-0.328	-0.664
SPT6	12	0	5.358	6	1	7	1.613	1.258	-1.299
OC1	13	0	5.239	6	1	7	1.676	-0.101	-0.836
OC2	14	0	5.269	6	1	7	1.653	0.727	-1.139
OC3	15	0	5.239	6	1	7	1.676	0.797	-1.163
OC4	16	0	5.201	6	1	7	1.582	0.598	-1.068
OC5	17	0	4.045	4	1	7	1.943	-1.276	0.004
OC6	18	0	5.493	6	1	7	1.727	1.351	-1.426
SSCP1	19	0	5.396	6	1	7	1.662	0.518	-1.083
SSCP2	20	0	5.418	6	1	7	1.716	1.18	-1.342
SSCP3	21	0	5.485	6	1	7	1.651	0.858	-1.24
SSCP4	22	0	5.433	6	1	7	1.704	1.068	-1.313
SSCP5	23	0	5.343	6	1	7	1.626	0.651	-1.086

Further analysis was performed by using PLS. In this step of analysis, reliability and validity was examined. In reliability, Cronbach alpha, factor loadings and composite reliability (CR) was investigated. Cronbach alpha, factor loadings and CR should be higher than 0.7 [31, 32]. Figure 3 shows that factor loadings is above 0.7. Table 2 shows that CR and alpha is also above 0.7. Moreover, average variance extracted (AVE) is above 0.5. Additionally, Table 3 highlighted the discriminant validity with the help of cross-loadings.

**Table 2.** Alpha, CR and AVE

	Alpha	rho A	CR	AVE
Management Support	0.963	0.964	0.97	0.846
Organization Culture	0.927	0.929	0.946	0.78
Sufficient Project Time	0.973	0.974	0.978	0.882
Sustainable Supply Chain Performance	0.96	0.962	0.969	0.864

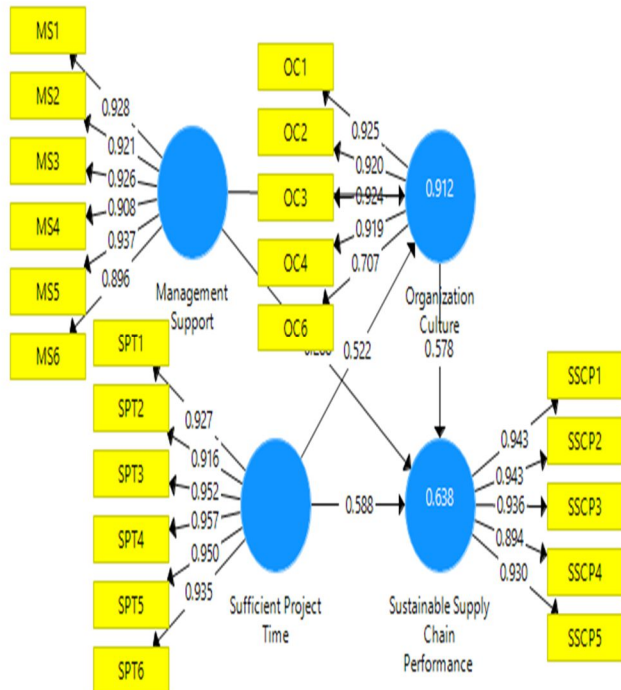

Figure 3. Confirmatory Factor Analysis

Table 3. Cross-Loadings

	Management Support	Organization Culture	Sufficient Project Time	Sustainable Supply Chain Performance
MS1	0.928	0.841	0.848	0.557
MS2	0.921	0.834	0.822	0.591
MS3	0.926	0.874	0.869	0.581
MS4	0.908	0.843	0.83	0.584
MS5	0.937	0.896	0.879	0.647
MS6	0.896	0.87	0.882	0.573
OC1	0.886	0.925	0.899	0.602
OC2	0.875	0.92	0.877	0.615
OC3	0.884	0.924	0.896	0.646
OC4	0.87	0.919	0.912	0.588
OC6	0.591	0.707	0.539	0.695
SPT1	0.854	0.873	0.927	0.573
SPT2	0.834	0.84	0.916	0.542
SPT3	0.891	0.897	0.952	0.625
SPT4	0.877	0.891	0.957	0.584
SPT5	0.887	0.89	0.95	0.6
SPT6	0.898	0.907	0.935	0.612
SSCP1	0.614	0.72	0.604	0.943
SSCP2	0.604	0.698	0.575	0.943
SSCP3	0.596	0.716	0.587	0.936
SSCP4	0.55	0.644	0.531	0.894
SSCP5	0.612	0.728	0.619	0.93

the recommended technique to test the hypotheses [33, 34]. Figure 4 shows the PLS bootstrapping and Table 4 and Table 5 shows the results of PLS bootstrapping. It is found that t-value for all the hypotheses is above 1.96 which supported all five hypotheses. Moreover, indirect effect of organization culture is shown in Table 5. It indicates that organizational culture is a mediating variable. R-square value is 0.638 which is substantial [35]. Thus, all the variables are expected to bring 63.8% change in sustainable supply chain performance.

Table 4. Direct Effect Results

	(O)	(M)	SD	T Statistics	P Values
Management Support -> Organization Culture	0.45	0.457	0.084	5.33	0
Management Support -> Sustainable Supply Chain Performance	0.288	0.312	0.135	2.143	0.041
Organization Culture -> Sustainable Supply Chain Performance	0.578	0.566	0.255	6.199	0
Sufficient Project Time -> Organization Culture	0.522	0.515	0.086	6.095	0
Sufficient Project Time -> Sustainable Supply Chain Performance	0.588	0.554	0.217	2.705	0.007

Table 5. Indirect Effect

	(O)	(M)	SD	T Statistics	P Values
Management Support -> Organization Culture -> Sustainable Supply Chain Performance	0.71	0.718	0.187	3.802	0
Sufficient Project Time -> Organization Culture -> Sustainable Supply Chain Performance	0.824	0.804	0.181	4.54	0

Finally, structural model was used to test the hypotheses with the help of PLS bootstrapping. PLS bootstrapping is

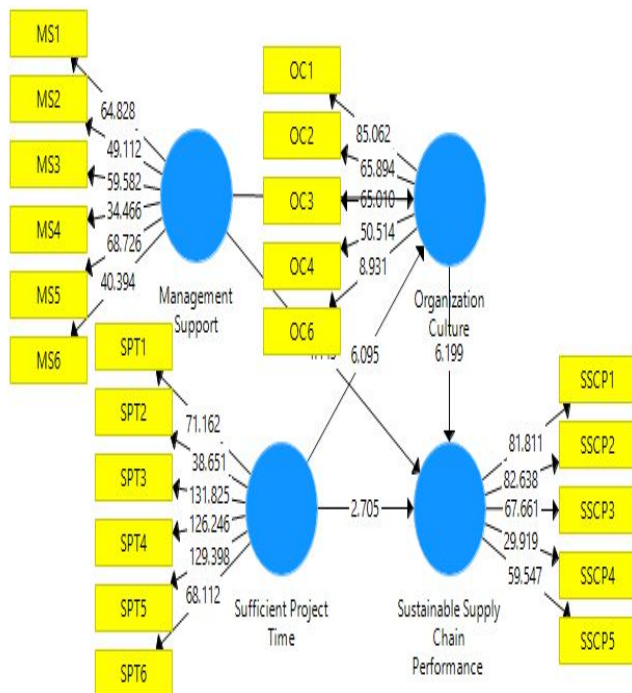

Figure 4. Structural Model

## 5. Conclusion

Objective of the current study was developed based on the fact that Indonesian textile companies were lacking in supply chain activities. Due to lack in supply chain, the business performance was not up to the mark. To cope this issue, this study examined various factors which may enhance the sustainable supply chain activities in Indonesian textile companies. For this purpose, three factors; management support, sufficient project time and organization culture were identified, and data were collected from the employees of Indonesian textile companies' employees. During this study, it was revealed that management support and sufficient project time has important role in sustainable supply chain. Management support and sufficient project time can promote supply chain by decreasing the issues in supply chain activities. It is found that management support and sufficient project time has positive influence to enhance sustainable supply chain. However, positive or supportive organization culture has important role to enhance the positive effect of management support and sufficient project time on supply chain. Textile companies should have supportive organization culture to encourage the employees. Therefore, it is recommended to the Indonesian textile companies to focus on management support, sufficient project time and organization culture to support sustainable supply chain performance

## References

- [1] H. B. Singhry, A. A. Rahman, and N. S. Imm, "Effect of advanced manufacturing technology, concurrent engineering of product design, and supply chain performance of manufacturing companies," *The International Journal of Advanced Manufacturing Technology*, Vol. 86, pp. 663-669, 2016.
- [2] A. Ali and M. Haseeb, "Radio frequency identification (RFID) technology as a strategic tool towards higher performance of supply chain operations in textile and apparel industry of Malaysia," *Uncertain Supply Chain Management*, Vol. 7, pp. 215-226, 2019.
- [3] S. Nadeem, A. K. Alvi, and J. Iqbal, "Performance Indicators of E-Logistic System with mediating role of Information and Communication Technology (ICT)," *Journal of Applied Economics & Business Research*, Vol. 8, 2018.
- [4] M. N. Ikram and D. A. Siddiqui, "Effect of Green supply chain management on environmental performance and export performance: A case study of Textile industries in Pakistan," Ikram, MN and Siddiqui, DA (2019). Effect of Green Supply Chain Management on Environmental Performance and Export Performance: A Case Study of Textile Industries in Pakistan. *Social Science and Humanities Journal*, Vol. 3, pp. 1006-1019, 2019.
- [5] B. Zamani, G. Sandin, M. Svanström, and G. M. Peters, "Hotspot identification in the clothing industry using social life cycle assessment—opportunities and challenges of input-output modelling," *The International Journal of Life Cycle Assessment*, Vol. 23, pp. 536-546, 2018.
- [6] J. G. Covin and M. P. Miles, "Corporate entrepreneurship and the pursuit of competitive advantage," *Entrepreneurship theory and practice*, Vol. 23, pp. 47-63, 1999.
- [7] M. Altaf, W. Hameed, S. Nadeem, and S. Arfan, "Successful Entrepreneurial Process as Contributor towards Business Performance in Banking: Moderating Role of Passion for Inventing," *South Asian Journal of Management Sciences*, Vol. 13, 2019.
- [8] T. Nguyen and T. Pham, "The effect of corporate entrepreneurship, organizational culture on supply chain management and business performance in chemical industry," *Uncertain Supply Chain Management*, Vol. 8, pp. 67-76, 2020.
- [9] S. A. A. Tipu and K. Fantazy, "Exploring the relationships of strategic entrepreneurship and social capital to sustainable supply chain management and organizational performance," *International Journal of Productivity and Performance Management*, Vol. 67, pp. 2046-2070, 2018.
- [10] M. A. Waller and S. E. Fawcett, "Click here to print a maker movement supply chain: How invention and entrepreneurship will disrupt supply chain design," *Journal of Business Logistics*, Vol. 35, pp. 99-102, 2014.
- [11] W. A. Umrani, "Moderating effect of organizational culture on the relationship between corporate entrepreneurship and business performance in Pakistan's banking sector," *Universiti Utara Malaysia*, 2016.
- [12] W. A. Umrani, K. M. Kura, and U. Ahmed, "Corporate entrepreneurship and business performance: The moderating role of organizational culture in selected banks in Pakistan," *PSU Research Review*, Vol. 2, pp. 59-80, 2018.

- [13] K. Lee, M. Makri, and T. Scandura, "The effect of psychological ownership on corporate entrepreneurship: Comparisons between family and nonfamily top management team members," *Family Business Review*, Vol. 32, pp. 10-30, 2019.
- [14] H. Chebbi, D. Yahiaoui, M. Sellami, I. Papisolomou, and Y. Melanthiou, "Focusing on internal stakeholders to enable the implementation of organizational change towards corporate entrepreneurship: A case study from France," *Journal of Business Research*, 2019.
- [15] J. Jubaedah, I. Yulivan, and A. R. A. Hadi, "The influence of financial performance, capital structure and macroeconomic factors on firm's value—evidence from textile companies at Indonesia stock exchange," *Applied Finance and Accounting*, Vol. 2, pp. 18-29, 2016.
- [16] S. Wahyuni and D. Nadapdap, "Does Labor Factors and Country Competitiveness Influence Country Attractiveness? A Study in Indonesian and Jordan Textile Industries," *A Study in Indonesian and Jordan Textile Industries* (August 25, 2015), 2015.
- [17] J. H. Chua, J. J. Chrisman, and P. Sharma, "Defining the family business by behavior," *Entrepreneurship theory and practice*, Vol. 23, pp. 19-39, 1999.
- [18] M. A. Mukhtar, N. A. Baloch, and S. R. Khattak, "Dynamic capability & firm performance: mediating role of learning orientation, organizational culture & corporate entrepreneurship: A case study of sme's of Pakistan," *Journal of Managerial Sciences*, Vol. 13, 2019.
- [19] D. F. Kuratko, J. S. Hornsby, and J. G. Covin, "Diagnosing a firm's internal environment for corporate entrepreneurship," *Business Horizons*, Vol. 57, pp. 37-47, 2014.
- [20] J. B. Hanna, J. B. Skipper, and D. Hall, "Mitigating supply chain disruption: the importance of top management support to collaboration and flexibility," *International Journal of Logistics Systems and Management*, Vol. 6, pp. 397-414, 2010.
- [21] W. Ul-Hameed, H. Mohammad, H. Shahar, A. Aljumah, and S. Azizan, "The effect of integration between audit and leadership on supply chain performance: Evidence from UK based supply chain companies," *Uncertain Supply Chain Management*, Vol. 7, pp. 311-328, 2019.
- [22] J. Kaur, R. Sidhu, A. Awasthi, S. Chauhan, and S. Goyal, "A DEMATEL based approach for investigating barriers in green supply chain management in Canadian manufacturing firms," *International Journal of Production Research*, Vol. 56, pp. 312-332, 2018.
- [23] M. Hashemi, M. M. Peydaei, and A. Khodadadi, "The impact of organizational factors of Customer Relationship Management (CRM) on CRM adoption in Tax Affairs Organization of Tehran," *International Journal of Advanced Studies in Humanities and Social Science*, Vol. 7, pp. 267-277, 2018.
- [24] J. A. Rodger, "Application of a fuzzy feasibility Bayesian probabilistic estimation of supply chain backorder aging, unfilled backorders, and customer wait time using stochastic simulation with Markov blankets," *Expert Systems with Applications*, Vol. 41, pp. 7005-7022, 2014.
- [25] S. Hussain, M. Rizwan, M. S. Nawaz, and W. ul Hameed, "Impact of Effective Training Program, Job Satisfaction and Reward Management System on the Employee Motivation with mediating role of Employee Commitment," *Journal of Public Administration and Governance*, Vol. 3, pp. 278-293, 2013.
- [26] A. Engelen, T. C. Flatten, J. Thalmann, and M. Brettel, "The Effect of Organizational Culture on Entrepreneurial Orientation: A Comparison between Germany and Thailand," *Journal of Small Business Management*, Vol. 52, pp. 732-752, 2014.
- [27] R. Dubey, A. Gunasekaran, S. J. Childe, D. Roubaud, S. F. Wamba, M. Giannakis, and C. Foropon, "Big data analytics and organizational culture as complements to swift trust and collaborative performance in the humanitarian supply chain," *International Journal of Production Economics*, Vol. 210, pp. 120-136, 2019.
- [28] R. Hemalatha, "Ceiling limit a potential instrument of urban change—a descriptive study on the series of amendments in the development of Bangalore City," *Asian Journal of Economics and Empirical Research*, Vol. 3, No. 1, pp. 11-16, 2016.
- [29] L. Huey Yiing and K. Zaman Bin Ahmad, "The moderating effects of organizational culture on the relationships between leadership behaviour and organizational commitment and between organizational commitment and job satisfaction and performance," *Leadership & Organization Development Journal*, Vol. 30, pp. 53-86, 2009.
- [30] T. Cadden, D. Marshall, P. Humphreys, and Y. Yang, "Old habits die hard: exploring the effect of supply chain dependency and culture on performance outcomes and relationship satisfaction," *Production Planning & Control*, Vol. 26, pp. 53-77, 2015.
- [31] J. Hair, C. L. Hollingsworth, A. B. Randolph, and A. Y. L. Chong, "An updated and expanded assessment of PLS-SEM in information systems research," *Industrial Management & Data Systems*, Vol. 117, pp. 442-458, 2017.
- [32] J. F. Hair, C. M. Ringle, and M. Sarstedt, "Partial least squares structural equation modeling: Rigorous applications, better results and higher acceptance," 2013.
- [33] J. F. Hair Jr, G. T. M. Hult, C. Ringle and M. Sarstedt, *A primer on partial least squares structural equation modeling (PLS-SEM)*: Sage Publications, 2016.
- [34] H. Harvey, "Bilateral J-Curve between Philippines and trading partners: Linear and non-linear approach," *Asian Economic and Financial Review*, Vol. 8, No. 2, pp. 131-144, 2018.
- [35] W. W. Chin, "The partial least squares approach to structural equation modeling," *Modern Methods for Business Research*, Vol. 295, pp. 295-336, 1998.